

DETAIL A

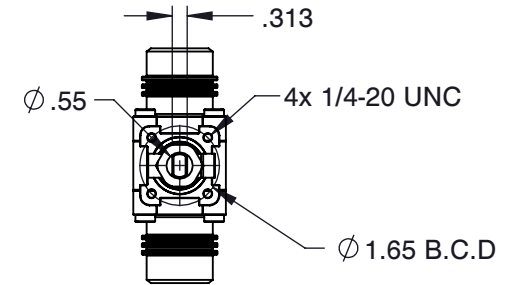

MOUNTING DIMENSIONS

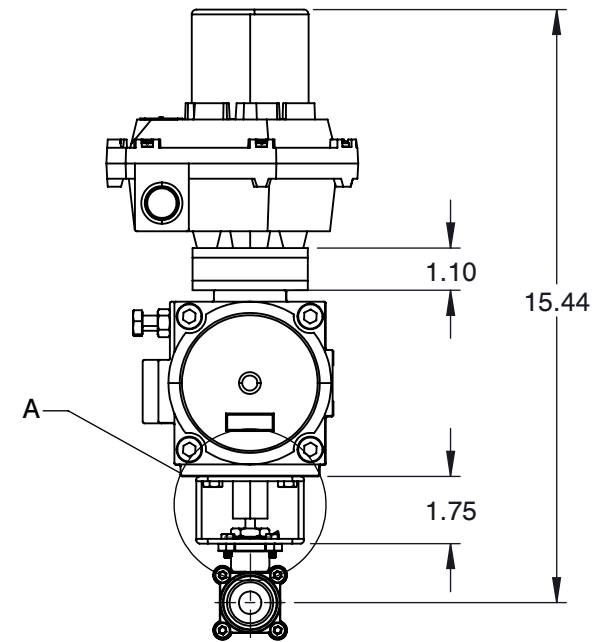
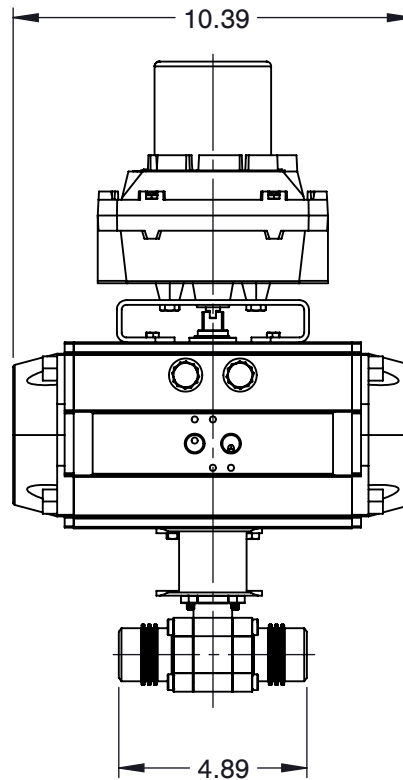

NOTES:

1. SIZE : 3/4"
2. PORT SIZE : REDUCED PORT
3. END CONNECTION : SOCKET WELD
4. PRESSURE RANGE : 720 PSI
5. TEMPERATURE RANGE : UP TO 1000 F



6910 West Ridge Road  
Fairview, PA 16415, USA  
Phone: (814) 474-2666  
Web: www.jareckivalves.net  
Email: sales@jareckivalves.net

THE INFORMATION CONTAINED HEREIN SHALL BE CONSIDERED THE SOLE PROPERTY OF JARECKI VALVES. THE RECIPIENT THEREOF AGREES NOT TO DISCLOSE SAID INFORMATION FOR ANY PURPOSE EXCEPT AS SPECIFIED BY JARECKI VALVES, BY WRITTEN PERMISSION.

Tolerances (Inch)  
.xx = ± .01  
.xxx = ± .005  
x° = ± 1°  
or As Note

SCALE

NTS

COMPONENT	ACTUATOR VALVES	
3/4-WR-W3E 3000 WOG  W SERIES with 095 Actuator	UNIT	
	INCH	
	SIZE	
	A	

# ORDERING INFORMATION

SIZE	- SERIES	PORT SIZE	SEAT	SEAT MATERIAL	BALL	BALL COATING	BODY	- CLASS	END CONNECTION	ACTUATION
1/2" TO 4"	W	F FULL R REDUCED	0 NONMETAL	B BORONIZING	A 316SST	B BORONIZING	A CF8M	W1 1500 WOG	A THREADED	095FC 095 ACTUATOR FAIL CLOSE  095FO 095 ACTUATOR FAIL OPEN
			1 O SEAT	C COLMONOY	F HASTELLOY	C CHROME	B WCB	W2 2250 WOG/ANSI 600#	B FLANGED	
			2 G SEAT	G GRAPHITE	G INCOLOY	E ENP	H Alloy 20	W3 3000 WOG/ANSI 600#	D BUTT WELD	
			4 P SEAT	M TANTALUM	H ALLOY 20	L COLMONOY	X 2205 SST	W4 4500 WOG/ANSI 900#/1500#	J JIC	
			5 P SEAT	CHROME OXIDE	I MONEL	R CHROME CARBIDE			E SOCKET WELD	
			>750F	P PEEK	X 2205 SST	W TUNGSTEN CARBIDE			T TUBE	
6 G SEAT	R CHROME CARBIDE					S SWAGELOK				
UNI-DIRECTIONAL	S STELLITE					C RTJ FLANGED				
1000 F MAX	T TFE									
	U UHMWPE									
	W TUNGSTEN CARBIDE									

Example:

2"	SERIES	FULL PORT	SPRING LOADED UNIDIRECTIONAL SEATS	STELLITE SEATS	316SS	CHROME	CF8M	2250 WOG	THREADED ENDS	095 ACTUATOR FAIL CLOSE
<b>2</b>	<b>W</b>	<b>F</b>	<b>4</b>	<b>S</b>	<b>A</b>	<b>C</b>	<b>A</b>	<b>W2</b>	<b>B</b>	<b>095FC</b>

### Ordering Information:

When placing an order or requesting a quotation, please provide as many details on the application as possible such as media type, temperature, pressure, pipe size, etc.

				COMPONENT	ACTUATOR VALVES	
	6910 West Ridge Road Fairview, PA 16415, USA Phone: (814) 474-2666 Web: www.jareckivalves.net Email: sales@jareckivalves.net	THE INFORMATION CONTAINED HEREIN SHALL BE CONSIDERED THE SOLE PROPERTY OF JARECKI VALVES. THE RECIPIENT THEREOF AGREES NOT TO DISCLOSE SAID INFORMATION FOR ANY PURPOSE EXCEPT AS SPECIFIED BY JARECKI VALVES, BY WRITTEN PERMISSION.	Tolerances (Inch) .xx = ± .01 .xxx = ± .005 x° = ± 1° or As Note	3/4-WR-W3E 3000 WOG	UNIT	
					INCH	
			SCALE	NTS	W SERIES with 095 Actuator	SIZE
						A