

DETAIL A

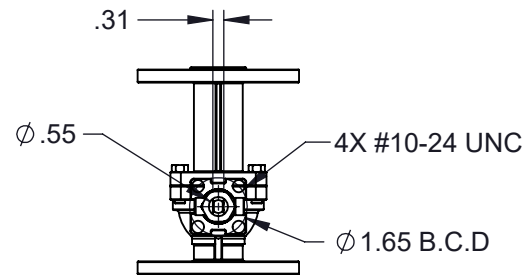

MOUNTING DIMENSIONS

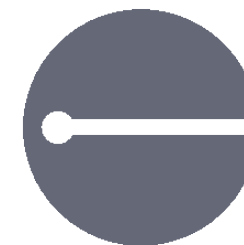

SLOT PORT (SL.125)

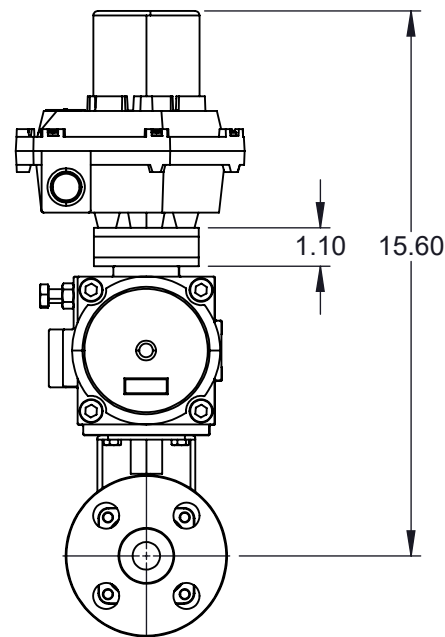
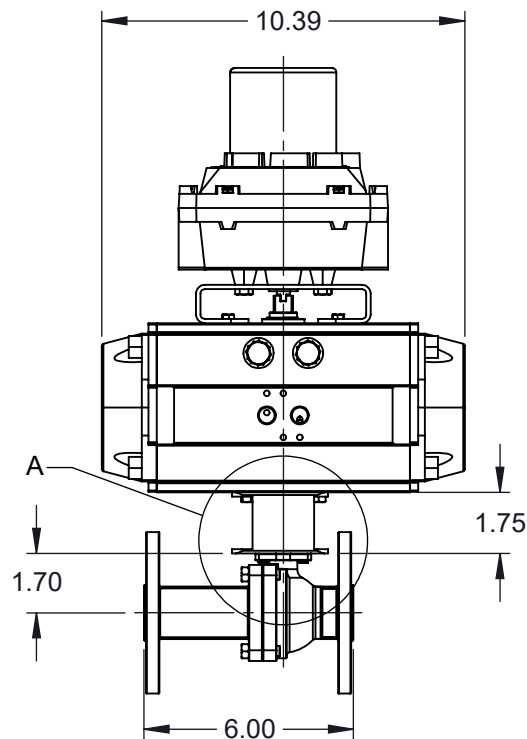

NOTES :

1. SIZE : 3/4"
2. PORT SIZE : SLOT PORT
3. END CONNECTION : FLANGED
4. PRESSURE RANGE : 720 PSI
5. TEMPERATURE RANGE : UP TO 1000 F



6910 West Ridge Road
 Fairview, PA 16415, USA
 Phone: (814) 474-2666
 Web: www.jareckivalves.net
 Email: sales@jareckivalves.net

THE INFORMATION CONTAINED HEREIN SHALL BE CONSIDERED THE SOLE PROPERTY OF JARECKI VALVES. THE RECIPIENT THEREOF AGREES NOT TO DISCLOSE SAID INFORMATION FOR ANY PURPOSE EXCEPT AS SPECIFIED BY JARECKI VALVES, BY WRITTEN PERMISSION.

Tolerances (Inch)
 .xx = ± .01
 .xxx = ± .005
 x° = ± 1°
 or As Note

SCALE

NTS

COMPONENT		ACTUATOR VALVES	
3/4-SVF-03BSL.125 300# ANSI		UNIT	
		INCH	
SV SERIES with 095 Actuator		SIZE	
		A	

ORDERING INFORMATION

SIZE	- SERIES	PORT SIZE	SEAT	SEAT MATERIAL	BALL	BALL COATING	BODY	- CLASS	END CONNECTION	ACTUATION	OPTIONS
1/4" TO 4"	SV	F FULL R REDUCED	0 NONMETAL	B BORONIZING	A 316SST	B BORONIZING	A CF8M	01 150# 03 300#	A THREADED	095FC 095 ACTUATOR FAIL CLOSE 095FO 095 ACTUATOR FAIL OPEN	V90 90DEG V V60 60DEG V V30 30DEG V V15 15DEG V SL12 SLOT.125 SL063 SLOT.063
			1 O SEAT	C COLMONOY	F HASTELLOY	C CHROME	B WCB		B FLANGED		
			2 G SEAT	G GRAPHITE	G INCOLOY	E ENP	H Alloy 20		D BUTT WELD		
			4 P SEAT	M TANTALUM	H ALLOY 20	L COLMONOY	X 2205 SST		J JIC		
			5 P SEAT	CHROME OXIDE	I MONEL	R CHROME CARBIDE			E SOCKET WELD		
			>750F	P PEEK	X 2205 SST	W TUNGSTEN CARBIDE			T TUBE		
			6 G SEAT	R CHROME CARBIDE					S SWAGELOK		
			UNI-DIRECTIONAL	S STELLITE					C RTJ FLANGED		
			1000 F MAX	T TFE							
				U UHMWPE							
				W TUNGSTEN CARBIDE							

Example:

2"	SERIES	FULL PORT	SPRING LOADED UNIDIRECTIONAL SEATS	STELLITE SEATS	316SS	CHROME	CF8M	2250 WOG	THREADED ENDS	095 ACTUATOR FAIL CLOSE
2	W	F	4	S	A	C	A	W2	B	095FC

Ordering Information:

When placing an order or requesting a quotation, please provide as many details on the application as possible such as media type, temperature, pressure, pipe size, etc.

				COMPONENT	ACTUATOR VALVES	
	6910 West Ridge Road Fairview, PA 16415, USA Phone: (814) 474-2666 Web: www.jareckivalves.net Email: sales@jareckivalves.net	THE INFORMATION CONTAINED HEREIN SHALL BE CONSIDERED THE SOLE PROPERTY OF JARECKI VALVES. THE RECIPIENT THEREIF AGREES NOT TO DISCLOSE SAID INFORMATION FOR ANY PURPOSE EXCEPT AS SPECIFIED BY JARECKI VALVES, BY WRITTEN PERMISSION.	Tolerances (Inch) .xx = ± .01 .xxx = ± .005 x° = ± 1° or As Note	3/4-SVF-03BSL.125 300# ANSI	UNIT	
					INCH	
			SCALE	NTS	SV SERIES with 095 Actuator	SIZE
						A