

DETAIL A

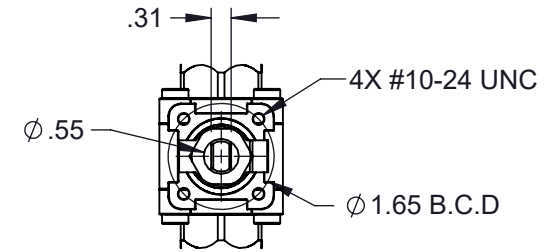

MOUNTING DIMENSIONS

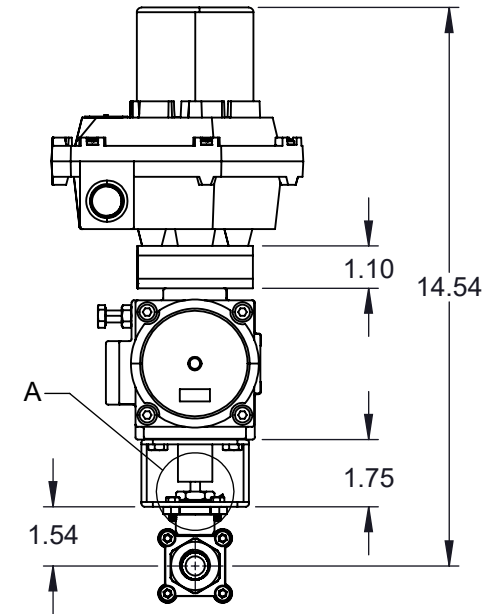
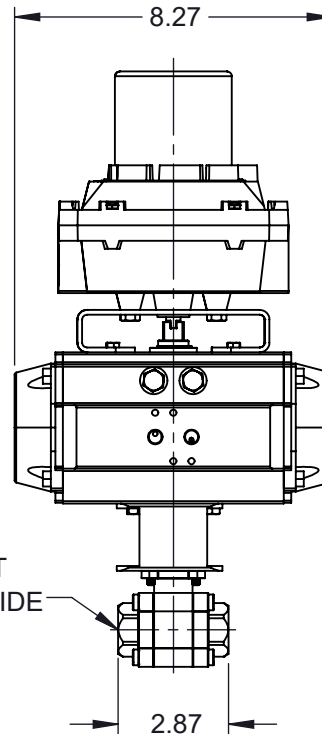

NOTES :

1. SIZE : 1/2"
2. PORT SIZE : REDUCED PORT
3. END CONNECTION : THREADED
4. PRESSURE RANGE : 720 PSI
5. TEMPERATURE RANGE : UP TO 1000 F

COMPONENT	ACTUATOR VALVES	
1/2-WR-W3A 3000 WOG W SERIES with 075 Actuator	UNIT	
	INCH	
	SIZE	
	A	



6910 West Ridge Road
Fairview, PA 16415, USA
Phone: (814) 474-2666
Web: www.jareckivalves.net
Email: sales@jareckivalves.net

THE INFORMATION CONTAINED HEREIN SHALL BE CONSIDERED THE SOLE PROPERTY OF JARECKI VALVES. THE RECIPIENT THEREIF AGREES NOT TO DISCLOSE SAID INFORMATION FOR ANY PURPOSE EXCEPT AS SPECIFIED BY JARECKI VALVES, BY WRITTEN PERMISSION.

Tolerances (Inch)
.xx = ± .01
.xxx = ± .005
x° = ± 1°
or As Note

SCALE NTS

ORDERING INFORMATION

SIZE	- SERIES	PORT SIZE	SEAT	SEAT MATERIAL	BALL	BALL COATING	BODY	- CLASS	END CONNECTION	ACTUATION
1/4" TO 4"	SV	F FULL R REDUCED	0 NONMETAL	B BORONIZING	A 316SST	B BORONIZING	A CF8M	W1 1500 WOG	A THREADED	095FC 095 ACTUATOR FAIL CLOSE 095FO 095 ACTUATOR FAIL OPEN
			1 O SEAT	C COLMONOY	F HASTELLOY	C CHROME	B WCB	W2 2250 WOG/ANSI 600#	B FLANGED	
			2 G SEAT	G GRAPHITE	G INCOLOY	E ENP	H Alloy 20	W3 3000 WOG/ANSI 600#	D BUTT WELD	
			4 P SEAT	M TANTALUM	H ALLOY 20	L COLMONOY	X 2205 SST	W4 4500 WOG/ANSI 900#/1500#	J JIC	
			5 P SEAT >750F	CHROME OXIDE	I MONEL	R CHROME CARBIDE			E SOCKET WELD	
			6 G SEAT	P PEEK	X 2205 SST	W TUNGSTEN CARBIDE			T TUBE	
			UNI-DIRECTIONAL 1000 F MAX	R CHROME CARBIDE				S SWAGelok		
				S STELLITE					C RTJ FLANGED	
				T TFE						
				U UHMWPE						
				W TUNGSTEN CARBIDE						

Example:

2"	SERIES	FULL PORT	SPRING LOADED UNIDIRECTIONAL SEATS	STELLITE SEATS	316SS	CHROME	CF8M	2250 WOG	THREADED ENDS	095 ACTUATOR FAIL CLOSE
2	W	F	4	S	A	C	A	W2	B	095FC

Ordering Information:

When placing an order or requesting a quotation, please provide as many details on the application as possible such as media type, temperature, pressure, pipe size, etc.

		COMPONENT	ACTUATOR VALVES		
 <p>6910 West Ridge Road Fairview, PA 16415, USA Phone: (814) 474-2666 Web: www.jareckivalves.net Email: sales@jareckivalves.net</p>	<p>THE INFORMATION CONTAINED HEREIN SHALL BE CONSIDERED THE SOLE PROPERTY OF JARECKI VALVES. THE RECIPIENT THEREOF AGREES NOT TO DISCLOSE SAID INFORMATION FOR ANY PURPOSE EXCEPT AS SPECIFIED BY JARECKI VALVES, BY WRITTEN PERMISSION.</p>	<p>Tolerances (Inch) .xx = ± .01 .xxx = ± .005 x° = ± 1° or As Note</p>	1/2-WR-W3A 3000 WOG		
			SCALE	NTS	
				W SERIES with 075 Actuator	UNIT
					INCH
			SIZE		
			A		