

DETAIL A

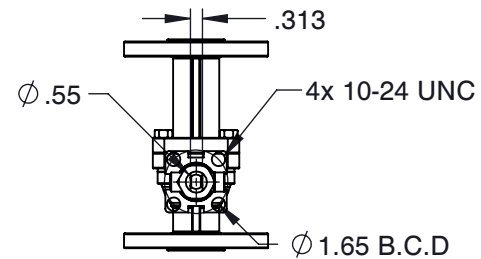

MOUNTING DIMENSIONS



V PORT (V15)

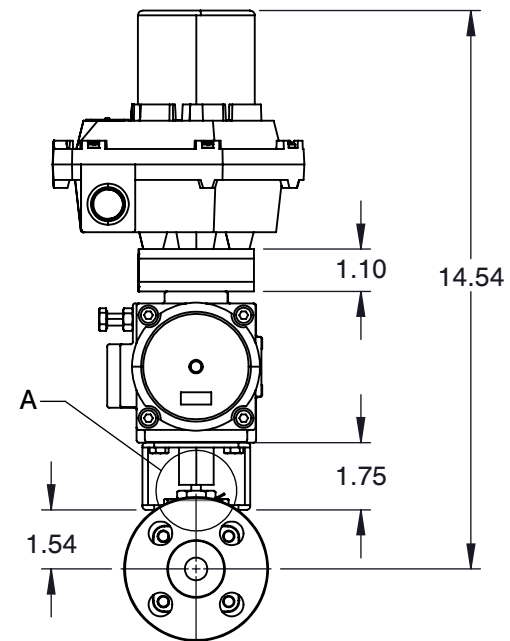
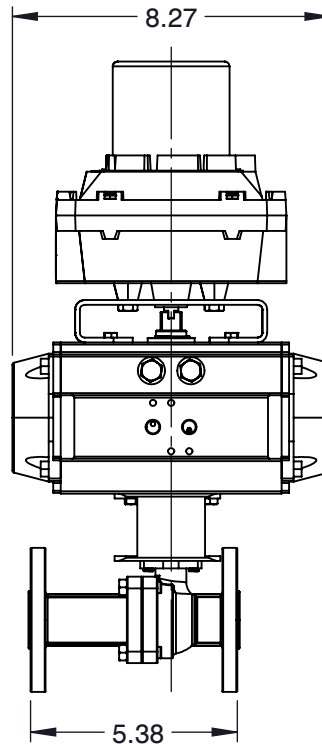

NOTES:

1. VALVE SIZE : 1/2"
2. PORT SIZE : V PORT
3. CLASS : 300#
4. END CONNECTION : FLANGED
5. PRESSURE RANGE : 720 PSI
6. TEMPERATURE RANGE : UP TO 1000 F



6910 West Ridge Road
 Fairview, PA 16415, USA
 Phone: (814) 474-2666
 Web: www.jareckivalves.net
 Email: sales@jareckivalves.net

THE INFORMATION CONTAINED HEREIN SHALL BE CONSIDERED THE SOLE PROPERTY OF JARECKI VALVES. THE RECIPIENT THEREOF AGREES NOT TO DISCLOSE SAID INFORMATION FOR ANY PURPOSE EXCEPT AS SPECIFIED BY JARECKI VALVES, BY WRITTEN PERMISSION.

Tolerances (Inch)
 .xx = ± .01
 .xxx = ± .005
 x° = ± 1°
 or As Note

SCALE

NTS

COMPONENT	ACTUATOR VALVES
	UNIT
	INCH
	SIZE
	A

1/2-SVF-03BV15
 300# ANSI

SV SERIES
 with 075 Actuator

ORDERING INFORMATION

SIZE	- SERIES	PORT SIZE	SEAT	SEAT MATERIAL	BALL	BALL COATING	BODY	- CLASS	END CONNECTION	OPTIONS	ACTUATION
1/2" TO 12"	SV	F FULL R REDUCED	0 NONMETAL 1 O SEAT 2 G SEAT 4 P SEAT 5 P SEAT >750F 6 G SEAT UNI-DIRECTIONAL 1000 F MAX	B BORONIZING C COLMONOY G GRAPHITE M TANTALUM CHROME OXIDE P PEEK R CHROME CARBIDE S STELLITE T TFE U UHMWPE W TUNGSTEN CARBIDE	A 316SST F HASTELLOY G INCOLOY H ALLOY 20 I MONEL X 2205 SST	B BORONIZING C CHROME E ENP L COLMONOY R CHROME CARBIDE W TUNGSTEN CARBIDE	A CF8M B WCB H Alloy 20 X 2205 SST	01 150# 03 300#	A THREADED B FLANGED D BUTT WELD J JIC E SOCKET WELD T TUBE S SWAGelok C RTJ FLANGED	V90 90DEG V V60 60DEG V V30 30DEG V V15 15DEG V SL12 SLOT.125 SL063 SLOT.063	075FC 075 ACTUATOR FAIL CLOSE 075FO 075 ACTUATOR FAIL OPEN

Example:

2"	SERIES	FULL PORT	SPRING LOADED UNIDIRECTIONAL SEATS	STELLITE SEATS	316SS	CHROME	CF8M	2250 WOG	THREADED ENDS	095 ACTUATOR FAIL CLOSE
2	W	F	4	S	A	C	A	W2	B	095FC

Ordering Information:

When placing an order or requesting a quotation, please provide as many details on the application as possible such as media type, temperature, pressure, pipe size, etc.

				COMPONENT	ACTUATOR VALVES
 <p>6910 West Ridge Road Fairview, PA 16415, USA Phone: (814) 474-2666 Web: www.jareckivalves.net Email: sales@jareckivalves.net</p>	<p>THE INFORMATION CONTAINED HEREIN SHALL BE CONSIDERED THE SOLE PROPERTY OF JARECKI VALVES. THE RECIPIENT THEREOF AGREES NOT TO DISCLOSE SAID INFORMATION FOR ANY PURPOSE EXCEPT AS SPECIFIED BY JARECKI VALVES, BY WRITTEN PERMISSION.</p>	<p>Tolerances (Inch) .xx = ± .01 .xxx = ± .005 x° = ± 1° or As Note</p>		<p>1/2-SVF-03BV15 300# ANSI</p> <p>SV SERIES with 075 Actuator</p>	UNIT
		SCALE	NTS		INCH
					SIZE
					A