

DETAIL A

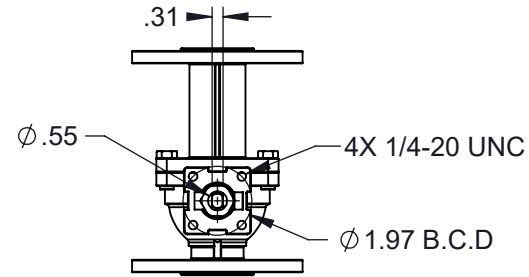

MOUNTING DIMENSIONS

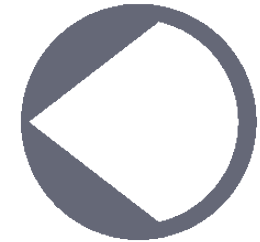

V PORT (V90)

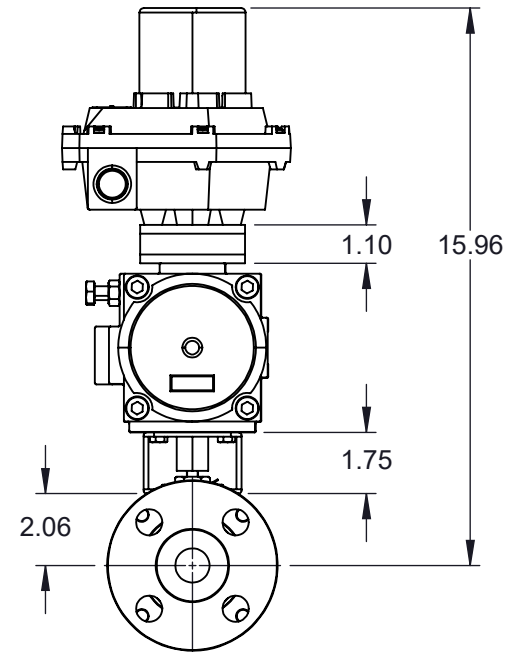
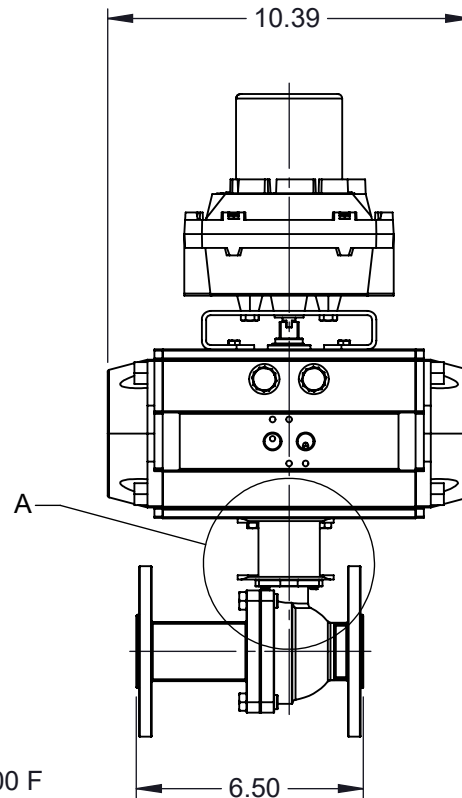

NOTES :

1. SIZE : 1"
2. PORT SIZE : V PORT
3. END CONNECTION : FLANGED
4. PRESSURE RANGE : 720 PSI
5. TEMPERATURE RANGE : UP TO 1000 F

COMPONENT		ACTUATOR VALVES	
1-SVF-03BV90 300# ANSI		UNIT	
		INCH	
SV SERIES with 095 Actuator		SIZE	
		A	



6910 West Ridge Road
Fairview, PA 16415, USA
Phone: (814) 474-2666
Web: www.jareckivalves.net
Email: sales@jareckivalves.net

THE INFORMATION CONTAINED HEREIN SHALL BE CONSIDERED THE SOLE PROPERTY OF JARECKI VALVES. THE RECIPIENT THEREOF AGREES NOT TO DISCLOSE SAID INFORMATION FOR ANY PURPOSE EXCEPT AS SPECIFIED BY JARECKI VALVES, BY WRITTEN PERMISSION.

Tolerances (Inch)
.xx = ± .01
.xxx = ± .005
x° = ± 1°
or As Note

SCALE NTS

ORDERING INFORMATION

SIZE	- SERIES	PORT SIZE	SEAT	SEAT MATERIAL	BALL	BALL COATING	BODY	- CLASS	END CONNECTION	ACTUATION	OPTIONS
1/4" TO 4"	SV	F FULL R REDUCED	0 NONMETAL 1 O SEAT 2 G SEAT 4 P SEAT 5 P SEAT >750F 6 G SEAT UNI- DIRECTIONAL 1000 F MAX	B BORONIZING C COLMONOY G GRAPHITE M TANTALUM CHROME OXIDE P PEEK R CHROME CARBIDE S STELLITE T TFE U UHMWPE W TUNGSTEN CARBIDE	A 316SST F HASTELLOY G INCOLOY H ALLOY 20 I MONEL X 2205 SST	B BORONIZING C CHROME E ENP L COLMONOY R CHROME CARBIDE W TUNGSTEN CARBIDE	A CF8M B WCB H Alloy 20 X 2205 SST	01 150# 03 300#	A THREADED B FLANGED D BUTT WELD J JIC E SOCKET WELD T TUBE S SWAGelok C RTJ FLANGED	095FC 095 ACTUATOR FAIL CLOSE 095FO 095 ACTUATOR FAIL OPEN	V90 90DEG V V60 60DEG V V30 30DEG V V15 15DEG V SL12 SLOT.125 SL063 SLOT.063

Example:

2"	SERIES	FULL PORT	SPRING LOADED UNIDIRECTIONAL SEATS	STELLITE SEATS	316SS	CHROME	CF8M	2250 WOG	THREADED ENDS	095 ACTUATOR FAIL CLOSE
2	W	F	4	S	A	C	A	W2	B	095FC

Ordering Information:

When placing an order or requesting a quotation, please provide as many details on the application as possible such as media type, temperature, pressure, pipe size, etc.

				COMPONENT	ACTUATOR VALVES
	6910 West Ridge Road Fairview, PA 16415, USA Phone: (814) 474-2666 Web: www.jareckivalves.net Email: sales@jareckivalves.net	THE INFORMATION CONTAINED HEREIN SHALL BE CONSIDERED THE SOLE PROPERTY OF JARECKI VALVES. THE RECIPIENT THEREIF AGREES NOT TO DISCLOSE SAID INFORMATION FOR ANY PURPOSE EXCEPT AS SPECIFIED BY JARECKI VALVES, BY WRITTEN PERMISSION.	Tolerances (Inch) .xx = ± .01 .xxx = ± .005 x° = ± 1° or As Note	1-SVF-03BV90 300# ANSI SV SERIES with 095 Actuator	UNIT
					INCH
			SIZE		
			A		
		SCALE	NTS		