

DETAIL A

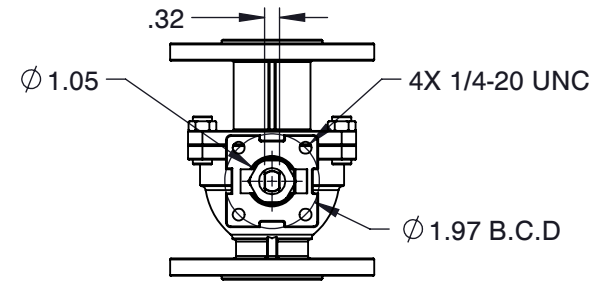

MOUNTING DIMENSION



V PORT (V15)

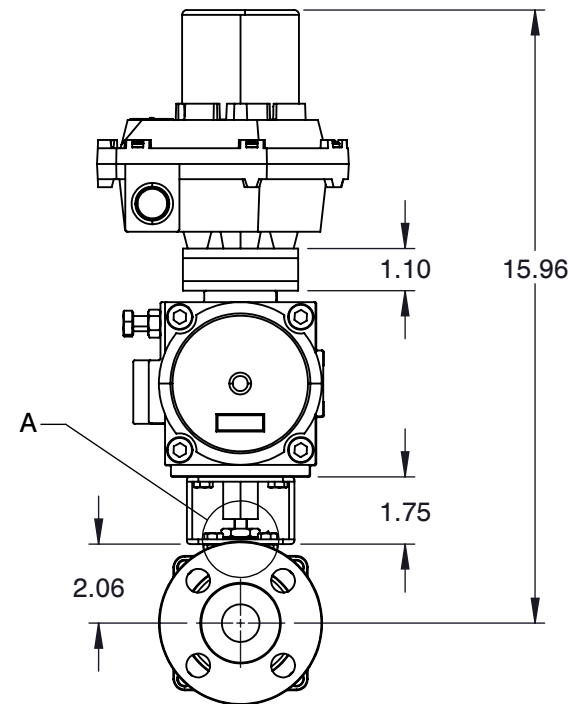
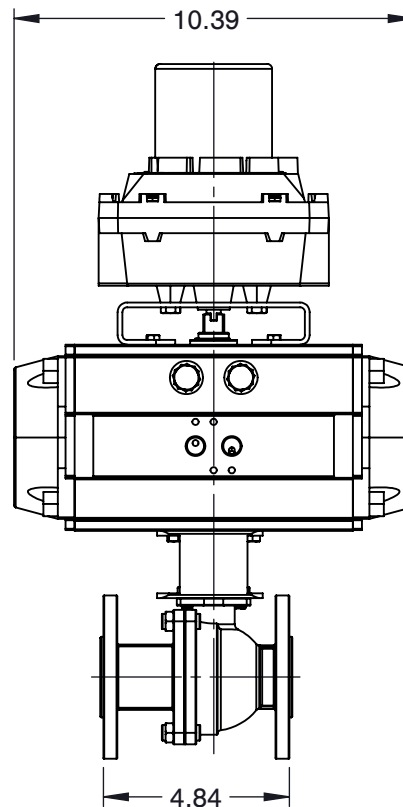

NOTES :

1. VALVE SIZE : 1"
2. PORT SIZE : V PORT
3. CLASS : 150#
4. END CONNECTION : FLANGED
5. PRESSURE RANGE : 720 PSI
6. TEMPERATURE RANGE : UP TO 1000 F



6910 West Ridge Road
Fairview, PA 16415, USA
Phone: (814) 474-2666
Web: www.jareckivalves.net
Email: sales@jareckivalves.net

THE INFORMATION CONTAINED HEREIN SHALL BE CONSIDERED THE SOLE PROPERTY OF JARECKI VALVES. THE RECIPIENT THEREOF AGREES NOT TO DISCLOSE SAID INFORMATION FOR ANY PURPOSE EXCEPT AS SPECIFIED BY JARECKI VALVES, BY WRITTEN PERMISSION.

Tolerances (Inch)
.xx = ± .01
.xxx = ± .005
x° = ± 1°
or As Note

SCALE

NTS

COMPONENT		ACTUATOR VALVES	
1-SVF-01BV15 150# ANSI		UNIT	
		INCH	
SV SERIES with 095 Actuator		SIZE	
		A	

ORDERING INFORMATION

SIZE	- SERIES	PORT SIZE	SEAT	SEAT MATERIAL	BALL	BALL COATING	BODY	- CLASS	END CONNECTION	OPTIONS	ACTUATION
1/2" TO 12"	SV	F FULL R REDUCED	0 NONMETAL	B BORONIZING	A 316SST	B BORONIZING	A CF8M	01 150# 03 300#	B FLANGED D BUTT WELD	V90 90 DEG V	095FC 095 ACTUATOR FAIL CLOSE 095FO 095 ACTUATOR FAIL OPEN
			1 O SEAT	C COLMONOY	F HASTELLOY	C CHROME	B WCB			V60 60 DEG V	
			2 G SEAT	G GRAPHITE	G INCOLOY	E ENP	H Alloy 20			V30 30 DEG V	
			4 P SEAT	M TANTALUM	H ALLOY 20	M TANTALUM	X 2205 SST			V15 15 DEG V	
			5 P SEAT	CHROME OXIDE	I MONEL	CHROME OXIDE				SL.12 SLOT.125	
			>750F	P PEEK	X 2205 SST	L COLMONOY				SL.063 SLOT.063	
				R CHROME CARBIDE		R CHROME CARBIDE					
				S STELLITE		S STELLITE					
				T TFE		T TFE					
				U UHMWPE		W TUNGSTEN CARBIDE					
	W TUNGSTEN CARBIDE		O NO COATING								

Example:

2"	SERIES	FULL PORT	SPRING LOADED UNIDIRECTIONAL SEATS	STELLITE SEATS	316SS	CHROME	CF8M	150#	FLANGED RF	90° V PORT
2	-SV	F	4	S	A	C	A	- 01	B	V90

Ordering Information:

When placing an order or requesting a quotation, please provide as many details on the application as possible such as media type, temperature, pressure, pipe size, etc.

				COMPONENT	ACTUATOR VALVES
 <p>6910 West Ridge Road Fairview, PA 16415, USA Phone: (814) 474-2666 Web: www.jareckivalves.net Email: sales@jareckivalves.net</p>	<p>THE INFORMATION CONTAINED HEREIN SHALL BE CONSIDERED THE SOLE PROPERTY OF JARECKI VALVES. THE RECIPIENT THEREOF AGREES NOT TO DISCLOSE SAID INFORMATION FOR ANY PURPOSE EXCEPT AS SPECIFIED BY JARECKI VALVES, BY WRITTEN PERMISSION.</p>	<p>Tolerances (Inch) .xx = ± .01 .xxx = ± .005 x° = ± 1° or As Note</p>		<p>1-SVF-01BV15 150# ANSI</p> <p>SV SERIES with 095 Actuator</p>	UNIT
		SCALE	NTS		INCH
					SIZE
					A