

DETAIL A

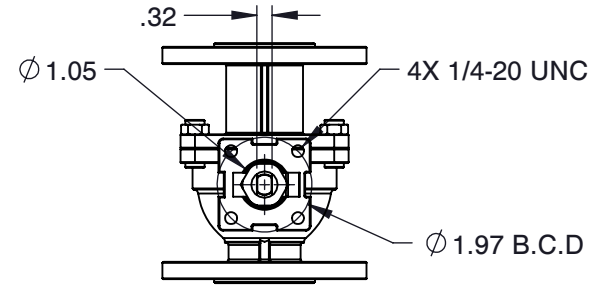

MOUNTING DIMENSION



SLOT PORT (SL.063)

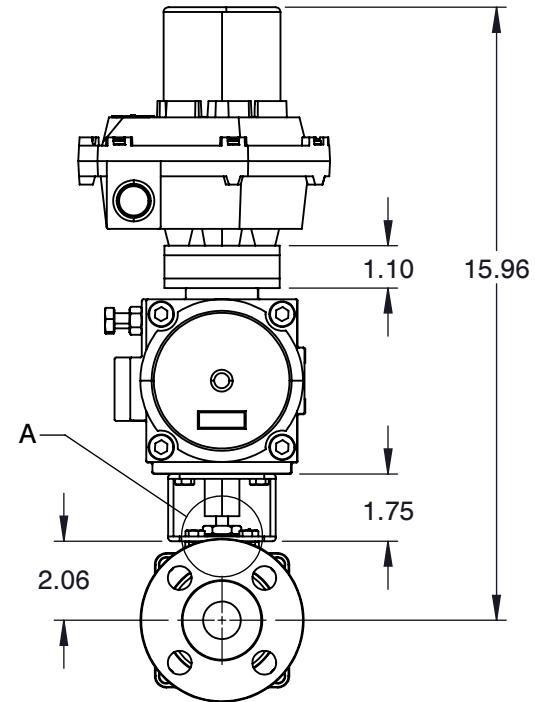
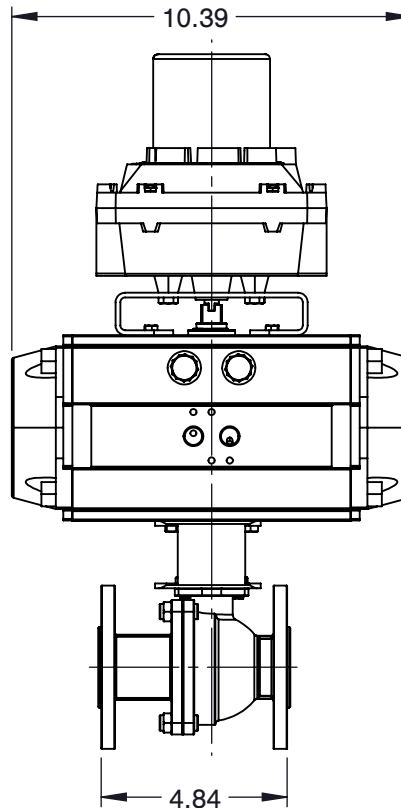

**NOTES :**

1. VALVE SIZE : 1"
2. PORT SIZE : SLOT PORT
3. CLASS : 150#
4. END CONNECTION : FLANGED
5. PRESSURE RANGE : 720 PSI
6. TEMPERATURE RANGE : UP TO 1000 F



6910 West Ridge Road  
 Fairview, PA 16415, USA  
 Phone: (814) 474-2666  
 Web: www.jareckivalves.net  
 Email: sales@jareckivalves.net

THE INFORMATION CONTAINED HEREIN SHALL BE CONSIDERED THE SOLE PROPERTY OF JARECKI VALVES. THE RECIPIENT THEREOF AGREES NOT TO DISCLOSE SAID INFORMATION FOR ANY PURPOSE EXCEPT AS SPECIFIED BY JARECKI VALVES, BY WRITTEN PERMISSION.

Tolerances (Inch)  
 .xx = ± .01  
 .xxx = ± .005  
 x° = ± 1°  
 or As Note

SCALE      NTS

COMPONENT		ACTUATORS VALVES	
1-SVF-01BSL-063 150# ANSI		UNIT	INCH
		SIZE	A
SV SERIES with 095 Actuator			

# ORDERING INFORMATION

SIZE	- SERIES	PORT SIZE	SEAT	SEAT MATERIAL	BALL	BALL COATING	BODY	- CLASS	END CONNECTION	OPTIONS	ACTUATION
1/2" TO 12"	SV	F FULL R REDUCED	0 NONMETAL 1 O SEAT 2 G SEAT 4 P SEAT 5 P SEAT >750F	B BORONIZING C COLMONOY G GRAPHITE M TANTALUM CHROME OXIDE P PEEK R CHROME CARBIDE S STELLITE T TFE U UHMWPE W TUNGSTEN CARBIDE	A 316SST F HASTELLOY G INCOLOY H ALLOY 20 I MONEL X 2205 SST	B BORONIZING C CHROME E ENP L COLMONOY R CHROME CARBIDE W TUNGSTEN CARBIDE	A CF8M B WCB H Alloy 20 X 2205 SST	01 150# 03 300#	B FLANGED D BUTT WELD	V90 90 DEG V V60 60 DEG V V30 30 DEG V V15 15 DEG V SL.12 SLOT.125 SL.063 SLOT.063	095FC 095 ACTUATOR FAIL CLOSE 095FO 095 ACTUATOR FAIL OPEN

Example:

2"	SERIES	FULL PORT	SPRING LOADED UNIDIRECTIONAL SEATS	STELLITE SEATS	316SS	CHROME	CF8M	#150	FLANGED RF	90° V PORT
<b>2</b>	<b>- SV</b>	<b>F</b>	<b>4</b>	<b>S</b>	<b>A</b>	<b>C</b>	<b>A</b>	<b>- 01</b>	<b>B</b>	<b>V90</b>

### Ordering Information:

When placing an order or requesting a quotation, please provide as many details on the application as possible such as media type, temperature, pressure, pipe size, etc.

095FC 095  
ACTUATOR FAIL  
CLOSE  
095FO 095  
ACTUATOR FAIL  
OPEN

COMPONENT	ACTUATOR VALVES
1-SVF-01BSL.063 150# ANSI	UNIT
SV SERIES with 095 Actuator	INCH
	SIZE
	A



6910 West Ridge Road  
Fairview, PA 16415, USA  
Phone: (814) 474-2666  
Web: www.jareckivalves.net  
Email: sales@jareckivalves.net

THE INFORMATION CONTAINED HEREIN SHALL BE CONSIDERED THE SOLE PROPERTY OF JARECKI VALVES. THE RECIPIENT THEREOF AGREES NOT TO DISCLOSE SAID INFORMATION FOR ANY PURPOSE EXCEPT AS SPECIFIED BY JARECKI VALVES, BY WRITTEN PERMISSION.

Tolerances (Inch)  
.xx = ± .01  
.xxx = ± .005  
x° = ± 1°  
or As Note

SCALE

NTS