

DETAIL C

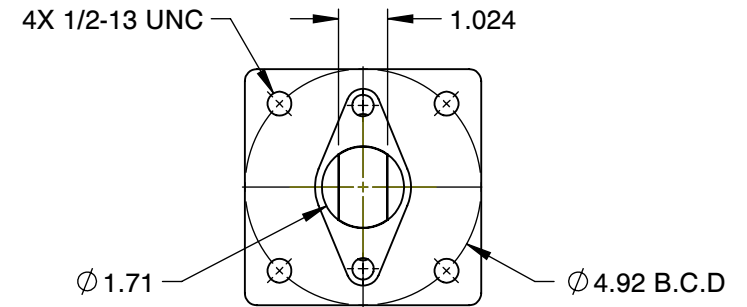

MOUNTING DIMENSIONS

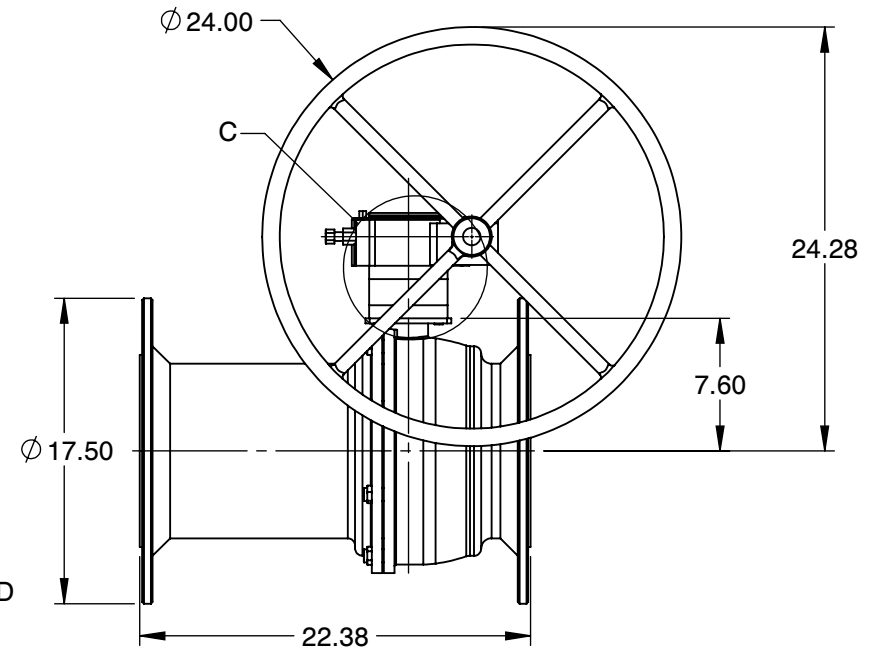
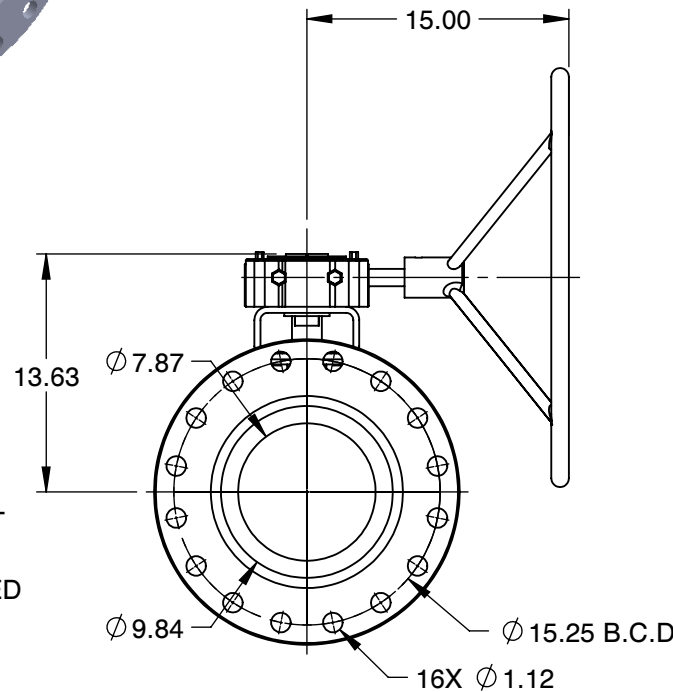

NOTES :

1. SIZE : 10"
2. PORT SIZE : REDUCED PORT
3. CLASS : 300#
4. END CONNECTION : FLANGED
5. WEIGHT : 279.5 LBS
6. Cv : 4000
7. PRESSURE RANGE : 720 PSI
8. TEMPERATURE RANGE : UP TO 1000 °F



6910 West Ridge Road  
Fairview, PA 16415, USA  
Phone: (814) 474-2666  
Web: www.jareckivalves.net  
Email: sales@jareckivalves.net

THE INFORMATION CONTAINED HEREIN SHALL BE CONSIDERED THE SOLE PROPERTY OF JARECKI VALVES. THE RECIPIENT THEREOF AGREES NOT TO DISCLOSE SAID INFORMATION FOR ANY PURPOSE EXCEPT AS SPECIFIED BY JARECKI VALVES, BY WRITTEN PERMISSION.

Tolerances (Inch)  
.xx = ± .01  
.xxx = ± .005  
x° = ± 1°  
or As Note

SCALE

NTS

COMPONENT

BALL VALVES

10-SVR-03B-GO  
300# ANSI

SV SERIES  
2-Piece Ball Valves

UNIT

INCH

SIZE

A

# ORDERING INFORMATION

SIZE	- SERIES	PORT SIZE	SEAT	SEAT MATERIAL	BALL	BALL COATING	BODY	- CLASS	END CONNECTION	OPTIONS
1/2" TO 12"	SV	F FULL	0 NONMETAL	B BORONIZING	A 316SST	B BORONIZING	A CF8M	01 150#	B FLANGED	V90 90 DEG V
		R REDUCED	1 O SEAT	C COLMONOY	F HASTELLOY	C CHROME	B WCB	03 300#	D BUTT WELD	V60 60 DEG V
			2 G SEAT	G GRAPHITE	G INCOLOY	E ENP	H Alloy 20			V30 30 DEG V
			4 P SEAT	M TANTALUM	H ALLOY 20	M TANTALUM	X 2205 SST			V15 15 DEG V
			5 P SEAT	CHROME OXIDE	I MONEL	CHROME OXIDE				SL.12 SLOT.125
			> 750F	P PEEK	X 2205 SST	L COLMONOY				SL.063 SLOT.063
				R CHROME CARBIDE		R CHROME CARBIDE				
				S STELLITE		S STELLITE				
				T TFE		T TFE				
				U UHMWPE		W TUNGSTEN CARBIDE				
				W TUNGSTEN CARBIDE		O NO COATING				

Example:

2"	SV SERIES	FULL PORT	SPRING LOADED UNIDIRECTIONAL SEATS	STELLITE SEATS	316SS	CHROME	CF8M	150#	FLANGED RF
<b>2</b>	<b>-SV</b>	<b>F</b>	<b>4</b>	<b>S</b>	<b>A</b>	<b>C</b>	<b>A</b>	<b>-01</b>	<b>B</b>

### Ordering Information:

When placing an order or requesting a quotation, please provide as many details on the application as possible such as media type, temperature, pressure, pipe size, etc.

				COMPONENT	BALL VALVES
	6910 West Ridge Road Fairview, PA 16415, USA Phone: (814) 474-2666 Web: www.jareckivalves.net Email: sales@jareckivalves.net	THE INFORMATION CONTAINED HEREIN SHALL BE CONSIDERED THE SOLE PROPERTY OF JARECKI VALVES. THE RECIPIENT THEREOF AGREES NOT TO DISCLOSE SAID INFORMATION FOR ANY PURPOSE EXCEPT AS SPECIFIED BY JARECKI VALVES, BY WRITTEN PERMISSION.	Tolerances (Inch) .xx = ± .01 .xxx = ± .005 x° = ± 1° or As Note	10-SVR-03B-GO 300# ANSI  SV SERIES 2-Piece Ball Valves	UNIT
					INCH
			SIZE		
			A		
			SCALE	NTS	